

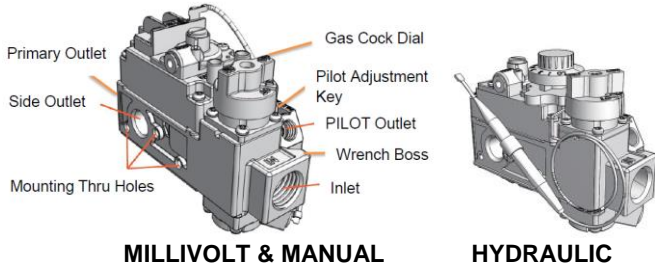

The **PUCADA Series gas valves** are designed for a wide variety of low capacity heating applications. Models are available for Millivolt, Manual and Hydraulic. Models are available with and without a pressure regulator. The gas valve can be mounted in multi position except upside down.



GAS CAPACITY SPECIFICATIONS

Capacity Btu/Hr	Natural	Propane
Minimum	5,000	5,000
Maximum	70,000	110,000
At 1" w.c. pressure drop	40,000	65,000

CAUTION

THIS DEVICE SHOULD BE INSTALLED BY A QUALIFIED SERVICE TECHNICIAN WITH REGARD FOR SAFETY AS IMPROPER INSTALLATION COULD RESULT IN A HAZARDOUS CONDITION.

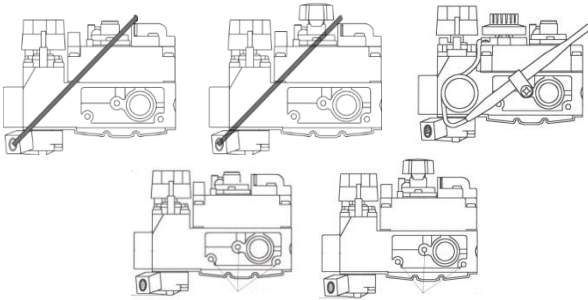

CAUTION

TURN OFF GAS SUPPLY AND ELECTRICAL POWER TO EQUIPMENT BEFORE SERVICING.

INSTALLATION INSTRUCTIONS

A. PIPING

- If replacement valve has multiple outlets (side outlets), be sure all unused outlets are plugged using the socket plugs provided.
- Pipe or tubing must be clean and free of scale and dirt.
- Make sure gas piping is pressure tested before gas valve is connected.
High pressure can damage gas valve causing a hazardous condition. Do not subject gas valve to more than 1/2 psi, (14" W.C.) inlet pressure.
- If it is not already installed, a drip leg (sediment trap) must be added to the gas supply line to gas valve. All piping must comply with local codes and ordinances and with National Fuel Gas Code (ANSI Z223. 1/NFPA, No. 54).
- Using pipe thread compound or tape (suitable for gas), apply a small amount on the male pipe threads. Leave the first two threads clean. Never use compound on female threads as it might be pushed into the control body.
- The gas valve can be mounted in multi position except upside down, (knobs facing ground position).
- Install gas valve so gas flow conforms to the inlet and outlet of the gas valve.

- DO NOT** insert any object other than suitable pipe or tubing in the inlet or outlet of this gas valve. Internal damage may occur and result in a hazardous condition. A backup wrench should only be used on the wrench boss provided for this purpose, never on the body of the gas valve, as this could distort the casting.

NOTE:

Do not overtighten any pipe connections, as this could crack the valve body. A valve with a cracked valve body will not be warranted

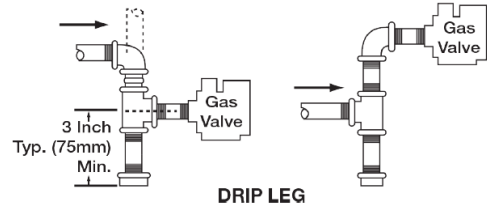

B. PILOT TUBING

- Make sure tubing is free of burrs and dirt.
- Pilot orifice should be checked and cleaned if necessary.
- Connect pilot tubing into the control using fitting provided, and tighten for a gas tight seal.

C. THERMOCOUPLE CONNECTION

- The thermocouple nut should be started and turned all the way in by hand. An additional quarter turn with a small wrench will then be sufficient to set the lock washer.

CAUTION: Overtightening may cause damage to the thermocouple or magnet and is unnecessary.

D. HYDRAULIC MODELS

- NOTE:** Capillary is liquid-filled and sharp bends are to be avoided.
- Sensing bulb positioning is important. Attach remote sensing bulb into the existing clips provided by the manufacturer of the equipment.

E. WIRING

- The millivolt gas valves are designed to operate with two-lead thermopiles having outputs of 250mV to 750mV.
- For proper operation of a millivolt system, the lead wires from the valve to the wall thermostat should not exceed the recommended maximum lengths shown in the table below:

Wire Gage	Maximum Length (ft)
14	100
16	64
18	40
20	25
22	16

- Typical wiring diagram as shown below.

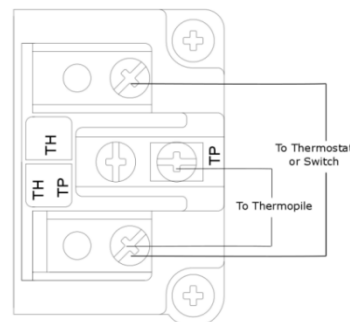



F. LEAK TEST

Test for gas leaks after valve installation with main burner on. Use a rich soapy water, and paint all piping and tubing joints liberally. Bubbles are indicative of a leak.

OPERATING INSTRUCTIONS

WARNING

L.P. GAS APPLICATIONS

To avoid possible injury, fire and explosion, please read and follow these precautions and all instructions on appliance before lighting the pilot. L.P. (Propane) gas is heavier than air and will remain at **floor level** if there is a leak. Before lighting, sniff at **floor level**. **If you smell gas**, follow these rules:

1. Get all people out of building.
2. **DO NOT** light matches. **DO NOT** turn electrical lights or switches on or off in area. **DO NOT** use an electric fan to remove gas from area.
3. Shut off gas at L.P. tank outside of building.
4. Telephone gas company and fire department. Ask instructions. Before hanging up, give your name, address, and phone number. **DO NOT** go back into the building. If help is coming, wait for them to arrive.

If L.P. tank runs out of fuel, turn off gas appliance. After L.P. tank is refilled, appliance must be relit according to manufacturer's instructions. If the gas valve has been exposed to **WATER** in any way, **DO NOT** try to use it. It must be replaced. **DO NOT** attempt repair on gas valve or appliance.

Tampering is **DANGEROUS** and voids all warranties.

LIGHTING OR RELIGHTING INSTRUCTIONS

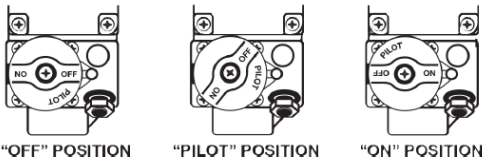

Dials must be operated by hand. **DO NOT** use pliers, wrenches or other tools to turn dials. The Gas Cock Dial has a dual function:

- A) Complete control of gas to pilot and main burner.
- B) When in pilot position, it is the reset mechanism for the automatic pilot. The Gas Cock Dial cannot be turned to "OFF" position without first depressing dial in "PILOT" position and then rotating to "OFF".

1. Depress and turn Gas Cock Dial to "OFF" position.
2. Turn wall thermostat to "OFF" or lowest setting.
3. Wait at least 5 minutes (10 minutes for L.P. gas) to allow gas which may have accumulated in burner compartment to escape.
4. Turn Gas Cock Dial to the "PILOT" position.
5. Hold match at pilot burner. **CAUTION:** If pilot lights without depressing Gas Cock Dial replace gas valve. Depress and hold Gas Cock Dial while lighting pilot burner. Allow pilot to burn approximately 1/2 ~ 1-1/2 minutes before releasing Gas Cock Dial. If pilot does not remain lighted, repeat operation allowing longer period before releasing Gas Cock Dial. (Adjust pilot, if necessary, as noted under "Pilot Burner Adjustment.") The thermocouple or thermopile may also be defective and should be checked out. (See **SERVICE INSTRUCTIONS**.)
6. Refer to specific model below

Millivolt Models

The appliance is now in operation. Turn Gas Cock Dial to "ON" position and set wall thermostat to required temperature. Allow burner to cycle on and off.

Hydraulic Models:

The appliance now is in operation. Turn Gas Cock Dial to "ON" position and turn temperature dial to desired position. Allow burner to cycle on and off.

Manual model only. The appliance now is in operation. Turn Gas Cock Dial to "ON" position when heat is required. Turn Gas Cock Dial to back to "PILOT" position when heat is no longer required.

CAUTION: Keep combustible material away from gas appliance. Keep burner area clean and free of dust and lint.

SERVICE INSTRUCTIONS

CAUTION:

If gas valve has been exposed to water in any way, it must be replaced. If gas valve fails to shut off, do not turn off electrical power. Turn off gas supply allowing fan or circulating pump (if so equipped) to continue running until system has cooled. Replace gas valve.

A. HOW TO CHECK MILLIVOLT OUTPUT

Before checking system, be certain wall thermostat lead wire does not exceed length recommended in **WIRING** Section Table, and all connections are clean and tight. Conduct each check shown in chart shown below by connecting meter test leads to terminals as indicated. All readings are closed circuit.

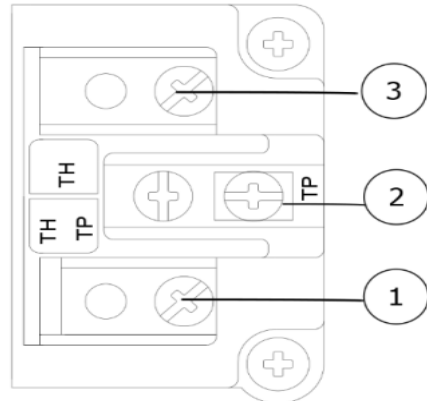

Component Check	Connect meter test leads to terminals	Switch or Thermostat contact should be	Meter mV Reading Should be	Test Result
Valve Operator System	2 & 3	Closed	Greater than 130	a
Thermopile and Magnet	1 & 2	Open	Greater than 350	b

a. TEST RESULTS

If the reading is more than 130 millivolts and the automatic valve does not come on, replace the valve. If the closed circuit reading is less than 130 millivolts, determine the cause by proceeding with steps "b"

b. TEST RESULTS

If "b" reading is less than 350 millivolts, clean and tighten all electrical connections and adjust pilot if necessary to increase millivolt output. If unable to adjust to at least the specified minimum, change the Thermopile.

B. PILOT BURNER ADJUSTMENT

Adjust pilot key to provide properly sized flame on the thermocouple or thermopile. The flame should cover the upper 3/8" of the tip.

IMPORTANT: Do not use GAS COCK DIAL to adjust gas output of the valve